

INSTRUCTION MANUAL FOR HDU DEVICE – STAND ALONE

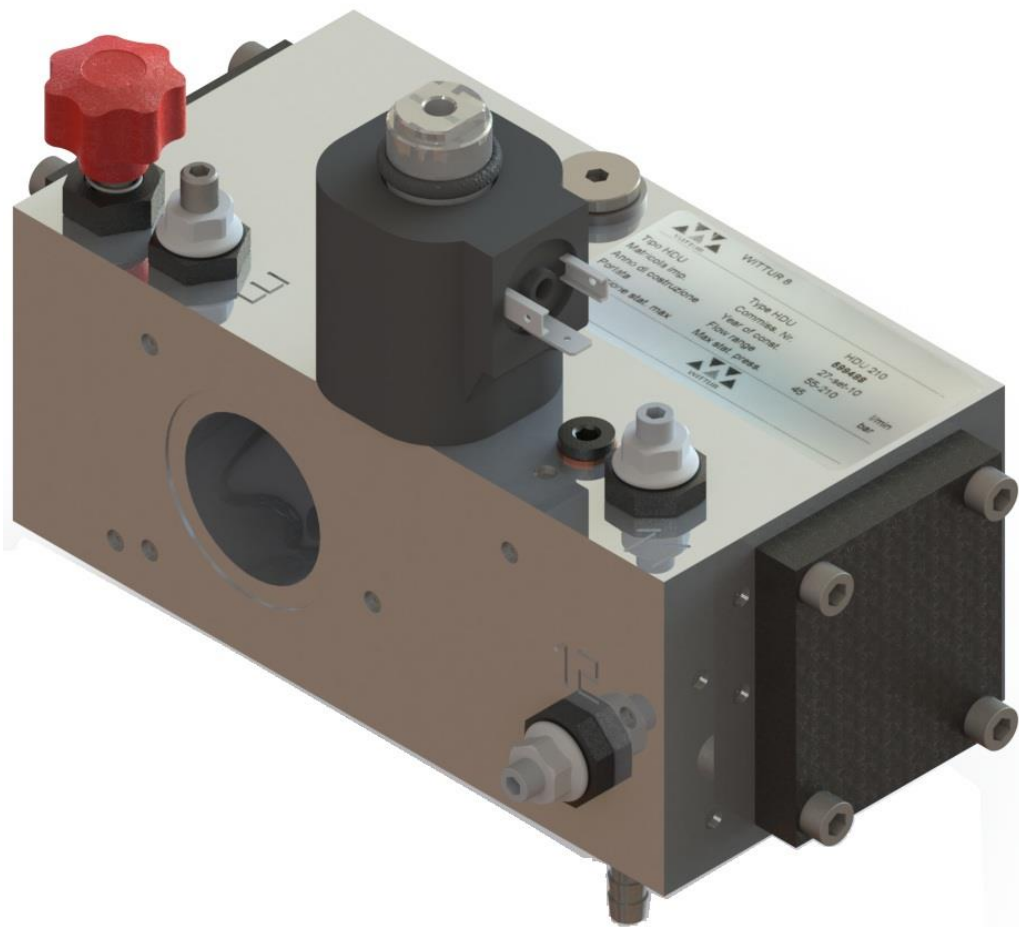

1.	General information before installing	3
1.1.	Introduction and description.....	3
1.2.	Liability and guarantee.....	3
1.3.	Safety measures.....	3
1.4.	Cleaning and anti-pollution measures	4
1.5.	Characteristics and choice of the oil.....	4
1.6.	Sizes, use ranges and weights of the HDU valve.....	4
1.7.	Content of supply	4
1.8.	Identification Plate	5
2.	Use and servicing.....	5
2.1.	Working principle	5
2.2.	Hydraulic diagram	5
2.3.	Mechanical connection	6
3.	Electrical connection	6
3.1.	Electrical connection of the HDU	6
3.2.	Notes about the wiring of the solenoid	6
3.3.	Prevention of uncontrolled movement of the car with HDU valves	7
3.4.	Sequence of command signal for normal travel and re-levelling.....	7
3.4.1.	HDU in redundant configuration	7
3.4.2.	HDU in braking configuration.....	8
3.5.	Self-monitoring check/test	8
4.	Controls and visual checks	9
4.1.	Check of the start in upward direction	9
4.2.	Check of the rupture valve intervention	9
4.3.	Check the rod counter-pressure and manual operation	9
4.4.	First installation: fault simulation.....	9
5.	Adjusting and regulation of HDU valve	9
5.1.1.	Rod counter-pressure and rope anti-loosening calibration: screw N°3	9
6.	Maintenance, inspection, repair and emergency rescue	10
6.1.	General information	10
6.2.	Oil leakage and car lowering	10
6.2.1.	Leakage inside the HDU valve group	10
6.2.2.	Leakage inside the hand emergency valve EM.....	11
6.2.3.	Leakage inside the downward travel electro-valve EVD HDU.	11
6.2.4.	Piloted non-return valve VBP.....	12
6.3.	Filter cleaning inside HDU valve.....	12
7.	Spare parts list and optional accessories	12
8.	Valve replacement	12
9.	TÜV Certificate: 95/16/EC – EN81-2 (example).....	14
10.	TÜV Certificate: 2014/33/EU – EN81-20/50	16
Attachment 1 :	Conformity verification of HDU as a brake application.....	18
A1.1.	Premise:.....	18
A1.2.	Determination of system characteristics:.....	18
A1.3.	Results evaluation	19
A1.4.	CALCULATION EXAMPLES	19
A1.4.1.	Example 1	19
A1.4.2.	Example 2.....	20
A1.4.3.	Example 3.....	20

1. General information before installing

1.1. Introduction and description

The assembly, installation, put into action and maintenance of the hydraulic lift has to be carried out only by trained staff. Before starting with any kind of work on the hydraulic components, it is necessary that the trained staff reads these operating instructions carefully; in particular chapters 1.3 Safety measures and 2. Use and servicing. This "Instruction Manual" is an integral part of the installation and must be kept in a safe and accessible place.

The HDU device (hereafter simply called "HDU") is an electrically commanded hydraulic valve operating in series with the downward valve inside the main control valve (hereafter simply called "MAIN VALVE") with the purpose to stop unintended car movement away from the landing door (UCM).

The HDU prevents an unintended car movement in downward direction only.

HDU valves are certified according to the European Lift Directive 95/16/EC and the new Lift Directive 2014/33/EU, therefore they are related to the European regulations EN81-2:1998+A3:2009 and the new normative EN81-20:2014, EN81-50:2014.

With the new Lift Directive 2014/33/EU, the protection devices against unintended control movement (HDU) have become safety devices for which is required the EC-type examination certificate.

Therefore, the EC-type examination certificate are reported in the following tables:

- **Directive 2014/33/EU – Normative EN81-20/50** (date of validity from 2016/04/20)

Valve	Certificate n.
HDU35	EU-UCM 022
HDU210	EU-UCM 019
HDU380	EU-UCM 020
HDU600	EU-UCM 021

The new certificate numbers will be valid also for the normative EN81-2.

The operating principle of HDU valve is to work together with the MAIN VALVE. According to the standard EN81-2:1998+A3:2009, chapter 9.13.3: and the new normative EN81-20 point 5.6.7.3 "In the case of using two electrically commanded hydraulic valves operating in series, self-monitoring implies separate verification of correct opening or closing of each valve under the empty car static pressure. If a

failure is detected, the next normal start of the lift shall be prevented"

1.2. Liability and guarantee

These operating instructions are addressed to staff competent in installing, adjusting and maintenance operations of hydraulic lifts.

OmarLift does not take responsibility for any kind of damage caused by use different from the one hereby explained, lack of experience, carelessness by people assigned to the assembling, repair operations of the hydraulic components.

OmarLift guarantee is not valid anymore if components or spare parts different from the original ones are installed, and if modifications or repair operations are carried out by non-authorized or non-qualified staff.

1.3. Safety measures

Installers and maintenance staff are fully responsible for their safety while working. All the safety measures in force have to be observed carefully to prevent damages or accidents to authorized staff or any possible non-authorized persons or objects, during the installation or maintenance works.

These operating instructions report some symbols, which correspond to important safety measures.



Danger:

This symbol draws attention to high risk of injury of persons. It must always be observed.



Warning:

This symbol draws attention to information which, if not observed, can lead to injury to persons or extensive damage to property. It must always be observed.



Caution:

This symbol draws attention to information containing important instructions for the use of the components.



Failure to observe the instructions can lead to damage or danger.

When assembling the hydraulic installation or replacing its components, it is necessary to:

- Always move the lift car to the bottom, so that it rests directly on the buffers;
- block the main power switch to be sure that the lift cannot be put into service unintentionally;
- bring the oil pressure to zero before opening any part of the hydraulic circuit, or removing any cap or unscrewing any fitting;

- prevent cinders and oxide from getting in contact with oil, rod and its seal and all the elastic parts of the installation during welding operations;
- get rid of the spilled oil, oil leakage, keep the installation always clean so that any leakage can be easily detected and removed.

1.4. Cleaning and anti-pollution measures

Dirt and impurities inside the hydraulic installation cause malfunctions and precocious wear.

All the installation components which are disassembled to be controlled or repaired, as well as pipes and fittings, have to be perfectly cleaned before being reassembled.

Possible spilled oil from the circuit during repair operations has not to be spread in the environment, but has to be promptly collected with clothes or sponges.



Oil contaminated waste has to be put in proper containers to prevent pollution of the environment.

Waste oil has to be carefully collected in proper containers to be then disposed of by specialized companies, according to the regulations in force in the country of operation.

1.5. Characteristics and choice of the oil

The hydraulic oil is a very important part of the hydraulic installation.



The oil has to be chosen taking into consideration the installation characteristics (temperature and ventilation of the machine room, installation traffic) as well as the temperature-viscosity characteristics of the oil.

OmarLift recommends using following oil types:

	Viscosity Index
HYDROFLUID 46 Base	101
HYDROFLUID 46 Plus	140
HYDROFLUID 46 High	160

Table 1 – Hydraulic oil characteristics



In case the oil needs to be replaced, comply with the anti-pollution and disposal regulations in force.

1.6. Sizes, use ranges and weights of the HDU valve

HDU valves are manufactured in different sizes and can be used in the following ranges and dimensions (see Figure 1, Table 2 and Table 3).

Valve Type	Nominal flow range [l/min]	Weight [kg]	Dimension L X D X H [mm]
HDU 35	8÷35	2	147 X 80 X 155
HDU 210	55-150	3.8	214 X 80 X 175
	180-210		
HDU 380	250-300	5.8	224 X 148 X 175
	380		
HDU 600	500-600	8.5	287 X 150 X 185

Table 2 – Dimension and weight of the valves

Valve Type	Flow range [l/min]	Press [bar]	Port A (see Figure 1)	Port B (see Figure 1)
HDU 35	8-35	10-50	G1/2" female thread	G1/2" female thread
HDU 210	55-150	10-45	G1"¼ female thread	G1"¼ female thread
	180-210	10-45	G1"¼ female thread	G1"½ female thread
HDU 380	250-300	10-45	G1"½ female thread	G1"½ female thread
	380	10-45	G1"½ female thread	G2" SAE Flange
HDU 600	450-600	10-45	G2" SAE Flange	G2" SAE Flange

Table 3 – Characteristics of HDU valves

In addition to previous data, these requirements are mandatory:

Oil Viscosity range: 25 ÷ 400cSt

Oil Temperature range: 0 ÷ 65°C

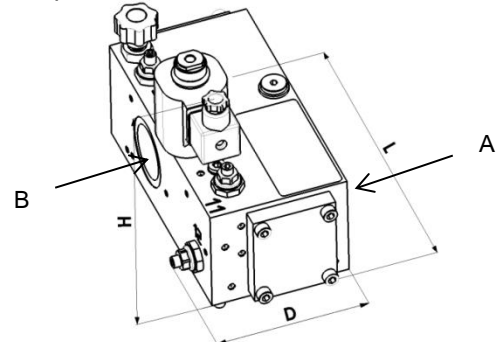

Figure 1 – Connection schema

1.7. Content of supply

When the material is collected, before signing the delivery document of the forwarding agent, check that the goods correspond to the list reported in the delivery document and to the requested order.

The content of supply covers:

- Instructions manual
- HDU valve (adjusted and calibrated at the factory)
- Fittings for connections
- Cardboard Box

1.8. Identification Plate

The identification plate showing the main valve data (see Figure below) is placed on the HDU valve. It consists of a name plate with following data:

- HDU valve type
- Serial number
- Year of construction
- Flow range
- Maximum static pressure



Figure 2 – Example of name plate

The QR code for the traceability of safety devices is printed on the labels. Within the QR code you can find some fields that identify the contents, such as the product name, release, revision, identification number, serial number, manufacturer name, etc..

2. Use and servicing

2.1. Working principle

The HDU is a downward pilot valve principally made up by an aluminum body. Inside the valve there is a piston (VBP) normally closed by the force of the spring.

The port A must be connected to the MAIN VALVE, the port B must be connected to the shut-off valve and then to the cylinder (see Figure 3)

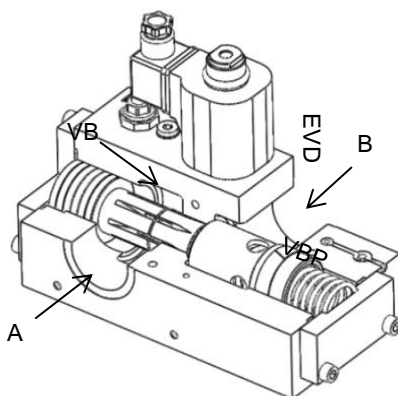

Figure 3 – Cross Section of a HDU valve

Subject to change without notice!

Upward movement:

During the elevator's upward travel with the pump running, oil flows through port A, the pressure of the oil is sufficient to open the piston VBP and the oil passes out through port B to the main cylinder. Solenoid EVD HDU is not energized.

Downwards movement:

During the elevator's downward travel, in addition to the CONTROL VALVE solenoid, the solenoid EVD HDU must be energized, causing the piston VBP to open. This happens because the oil flows behind the VBS piston, which pushes the VBP piston in the open position, allowing the oil to flow from port B to port A up to the cylinder (through the MAIN VALVE).

2.2. Hydraulic diagram

The Figure 4 shows the hydraulic diagram of the HDU valve:

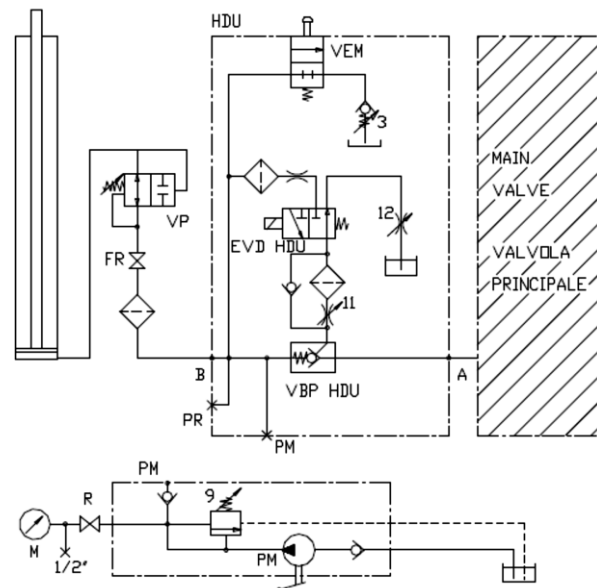

Legend:

- EVD HDU = Downward travel electro-valve of HDU
- VBP HDU = Downward pilot valve
- PR = Inlet for the pressure switch
- VEM = Emergency
- VP = Rupture valve
- FR = Shut-off valve filter
- PM = Hand pump
- 3 = Rod counter-pressure and rope anti-loosening calibration: screw N°3
- 11 = Start downward acceleration: screw N°11
- 12 = Downward stop: screw N°12

Figure 4 – Hydraulic diagram of the HDU valve

2.3. Mechanical connection

When assembling the HDU valve, the following points have to be observed:

- Only use the material recommended by OMARLIFT (especially the hydraulic oil) and the original OMARLIFT spare parts;
- Avoid the use of sealing materials such as silicone, plaster or hemp which could penetrate into the hydraulic circuit;

The HDU device is assembled between the cylinder and the MAIN VALVE as shown in the following figure:

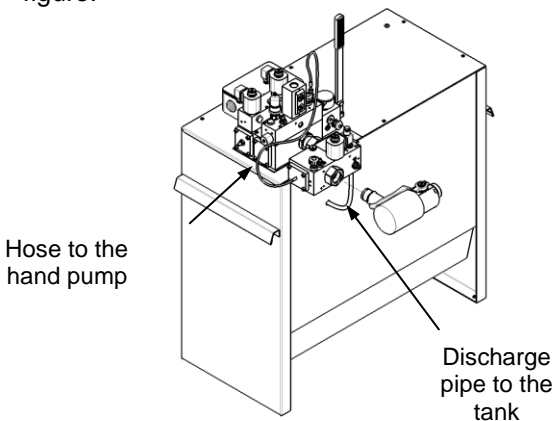

Figure 5 – HDU assembly position

The connection between the MAIN VALVE and the HDU is made by means of fittings (burst 350 bar) supplied by OmarLift (see Figure 6)



Figure 6 - Adapter

The hand pump is connected to the HDU by a hose (according to standard EN81-2 – and EN81-20 - 8 times max. static pressure) (see Figure 5).

The pipe that permits the oil to go into the tank is a standard plastic pipe (inside the atmospheric pressure tank) (see Figure 5).

3. Electrical connection

3.1. Electrical connection of the HDU

The HDU device requires the activation of the electro-valve EVD HDU.

Electrical connection has to be carried out by qualified staff, observing the specific instructions.



Before starting any operation it is mandatory to switch off the main power switch.

The EVD of the HDU is connected on the main controller separately from the downward electro-valve of the MAIN VALVE (see Figure 7). The activation sequence is described in the next chapters.

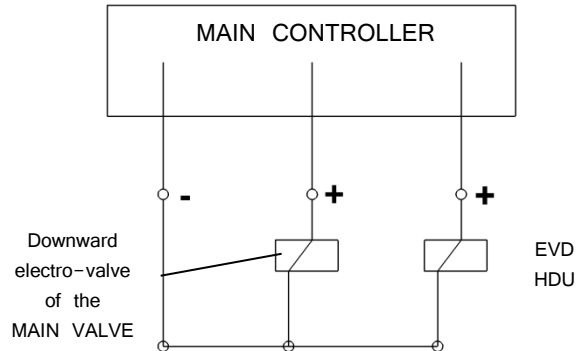

Figure 7 – Wiring diagram

3.2. Notes about the wiring of the solenoid

The solenoid can be single or double; for the single one refer to the “main coil”; in case of double solenoid refer both to “main coil” and “emergency coil” (see Figure 8).

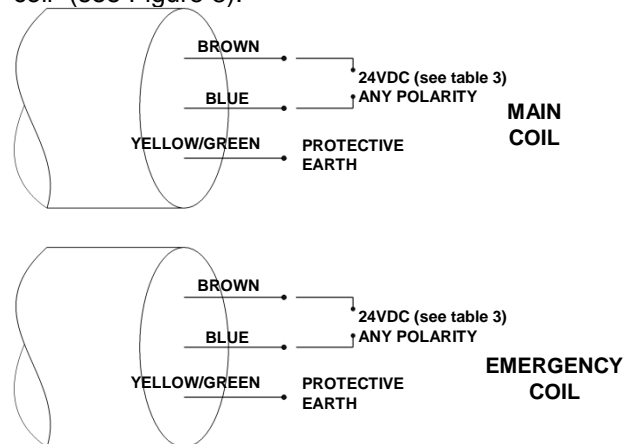

Figure 8 – Solenoid wiring diagram

The Table 4 shows all possible coils, which are all class H (180°C), ED 100%.

Type	Main coil voltage	Emergency coil voltage	Max. power consumpt.
12 VDC	12 VDC	==	24W 36W 45W
24 VDC	24 VDC	==	
48 VDC	48 VDC	==	
60 VDC	60 VDC	==	
80 VDC	80 VDC	==	
110 VDC	110 VDC	==	
180 VDC	180 VDC	==	
220 VDC	220 VDC	==	
220 VAC	220 VAC	==	
12 VDC/12 VDC	12 VDC	12 VDC	
24 VDC/12 VDC	24 VDC	12 VDC	
48 VDC/12 VDC	48 VDC	12 VDC	

60 VDC/12 VDC	60 VDC	12 VDC
80 VDC/12 VDC	80 VDC	12 VDC
110 VDC/12 VDC	110 VDC	12 VDC
180 VDC/12 VDC	180 VDC	12 VDC
220 VDC/12 VDC	220 VDC	12 VDC
220 VDC/24 VDC	220 VDC	24 VDC
220 VAC/24 VDC	220 VAC	24 VDC

Table 4 – Available solenoids

3.3. Prevention of uncontrolled movement of the car with HDU valves

UPWARDS:

- According to EN81-2 chapter 12.4.1 and EN81-20 chapter 5.9.3.4.2 “the supply to the electric motor shall be interrupted by at least two independent contactors, the main contacts of which shall be in series in the motor supply circuit”.

DOWNWARDS:

The concept is to use two electrically commanded hydraulic valves operating in series (HDU valve plus downward valve of MAIN VALVE).

When the car reaches the floor or when an UCM is detected, the solenoids of downwards EVD of the MAIN VALVE and EVD HDU are deactivated. At this point the mobile shutters close the passage of the oil and the car stops. The safety is guaranteed by a double valve operating in series, and the prevention of problems in downward direction is assured by a self-monitoring redundancy check.

3.4. Sequence of command signal for normal travel and re-leveling

3.4.1. HDU in redundant configuration

In the redundant configuration, the HDU valve is used as a second safety valve, operating in series with the main valve, and it guarantee that the car remain stationary, because **any UCM is prevented**. In the Figure 9 is shown how to manage the HDU and the MAIN VALVE (in this case is used the OmarLift main valve sequence) in order to control the lift.

Legend:

EVD HDU = Downward travel electro-valve of HDU

P = Upward travel

R = Upward travel deceleration

S = Stop during upward travel

L = Downward travel

Q = Downward travel deceleration

T = Stop during downward travel

RU = Re-leveling upward travel

RD = Re-leveling downward travel

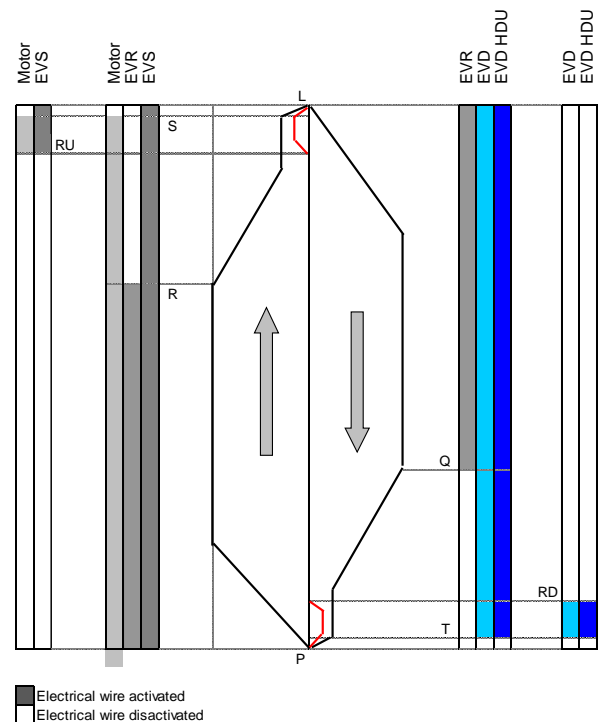

Figure 9 – HDU in redundant configuration: sequence of command of MAIN and HDU valves

The correct sequence for the complete system is described below:

UPWARDS:

P – Upward travel:

- Feed motor and coil “EVR”
- Feed coil “EVS” for λ - Δ start or soft starter

R – Upward travel deceleration:

- Deactivate “EVR”

S – Stop during upward travel:

- Stop motor (deactivate “EVS”, if present, with about 1” delay after the motor)

DOWNWARDS:

L – Downward travel:

- Feed coils “EVD”, “EVD HDU” and “EVR”

Q – Downward travel deceleration:

- Deactivate “EVR”

T – Stop during downward travel:

- Deactivate “EVD” and “EVD HDU”

RE-LEVELLING UPWARDS:

RU – Upward travel:

- Feed coil “EVS” for λ - Δ start or soft starter

S – Stop during upward travel:

- Stop motor (deactivate “EVS”, if present, with about 1” delay after the motor)

RE-LEVELLING DOWNWARDS:

RD – Downward travel:

- Feed coils “EVD”, “EVD HDU”

- T – Stop during downward travel:
- Deactivate “EVD” and “EVD HDU”

Re-levelling with open doors is only allowed in the unlocking zone (according to chapter 7.7.1 of EN81-2 and the chapter 5.3.8.1 of EN81-20) with maximum re-levelling speed of 0.3 m/s.

3.4.2. HDU in braking configuration

In the braking configuration, the HDU valve is always used as a second safety valve, operating in series with the main valve, but with different activation time, because in this case the valve must guarantee **the stop of the car in the event an unintended car movement (UCM) is detected** by at least one switching device with safety contact (§9.13. EN81-2 and §5.6.7 EN81-20).

Considering that, the activation of the EVD HDU solenoid, must occur before the activation of the EVD solenoid of the main valve, and the deactivation of the EVD HDU solenoid must occur after the deactivation of the EVD solenoid of the main valve.

The advance or delay must be in the order of 100-300msec.

As well as in the redundant configuration, also in the braking configuration, the lack of electrical power must stop the elevator car and maintain it stationary.

The Figure 10 shows how to manage the HDU valve in braking configuration and the MAIN VALVE, to control the elevator.



To a correct use of OmarLift HDU valve in braking configuration under all possible conditions, it is mandatory to check the application by means of the procedure described in Attachment 1: Conformity verification of HDU as a brake application.

Legend:

EVD HDU = HDU downward electro-valve

P = Upward travel

R = Upward travel deceleration

S = Stop during upward travel

L = Downward travel

Q = Downward travel deceleration

T = Stop during downward travel

RU = Re-levelling upward travel

RD = Re-levelling downward travel

HDU FRENANTE- HDU AS A BRAKE

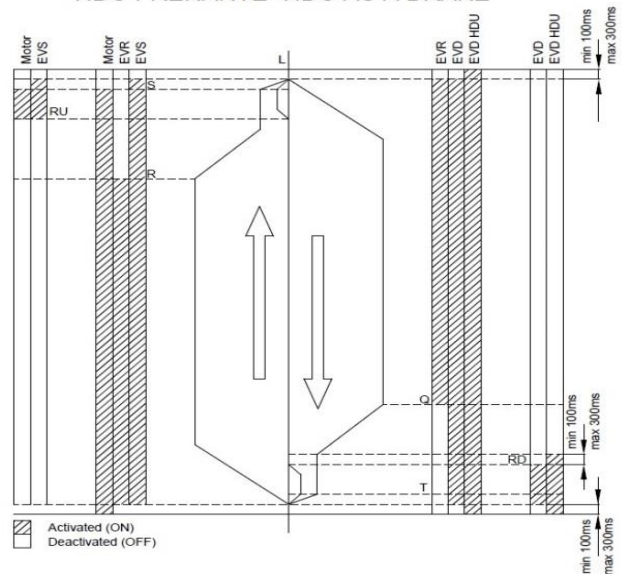

Figure 10 - HDU in braking configuration: activation sequence of main and HDU valves.

For the description of the system’s sequence, refer to 3.4.1 taking into consideration the advance or delay time mentioned before for the activation of EVD HDU compared to the other activations, as shown in Figure 10.

3.5. Self-monitoring check/test

The operation of both valves must be separately guaranteed and monitored. Check the correct opening and closing of each valve under empty static pressure.

15 minutes after stopping, according to the requirement of standards, the car must be brought to the ground floor; afterwards, during this safety operation, the self-monitoring test will be done:

In detail, the self-monitoring test will be done as follows:

- Energize the solenoid of EVD CONTROL VALVE for a few seconds (10 sec.)
- Using the re-levelling magnet, check if the car is moving from the floor (the distance below the floor must not exceed 20 mm)
- Make the re-levelling and bring the car to the floor (this step is necessary to completely refill oil into the rooms inside the HDU and the MAIN VALVE)
- Energize the solenoid of EVD HDU for a few seconds (10 sec.)
- Using the re-levelling magnet, check if the car is moving from the floor (the distance below the floor must not exceed 20 mm).

Depending on the test result:

- If the car has not reached the re-levelling sensor the lift has to be kept into service;

- if the car has passed over the re-levelling sensor, the lift must be put **out of service** and the safety circuit must be cut (according to the requirement of EN81-2 A3 and EN81-20).

Only a maintainer can put the elevator into service again, according to the requirements previously specified; this means that the operator must check (according to the instruction manual) the operation of the device and if necessary replace some items that have caused the defect.

In case of re-levelling in downward travel and power failure the safety circuit for re-levelling switches off the coils EVD HDU (and the downward electro-valve of the MAIN VALVE too) causing the closing of the HDU piston and the stop of the elevator car.

4. Controls and visual checks

After the assembling operations have been completed, the oil has been filled and the air has been purged from the circuit, it is proper to make the following checks:

4.1. Check of the start in upward direction

In order to get a smooth start of the motor in upward direction without load, follow the procedure below: With the shut-off valve closed, discharge static pressure by using the emergency button, then restart the motor and check that the pressure rises slowly from its minimum to its maximum value.

4.2. Check of the rupture valve intervention

Be sure that the rupture valve has already been calibrated. If necessary, adjust it according to the handbook for the adjusting operations. The downward travel intervention test has to be carried out by feeding the EVD solenoid of the HDU valve.

4.3. Check the rod counter-pressure and manual operation

For indirect acting installations 2:1, check that, with the car is blocked on the proper parachutes or laid on its dampers, by activating the red emergency button, the rod does not go down causing the ropes to loosen. If necessary, tighten screw n. 3 until it stops.



For any kind of installation, check that, when the car is free to go down, it goes down regularly at a reduced speed when the emergency button is pushed.

4.4. First installation: fault simulation

To check and assure the perfect operation of HDU simulate defects in this way:

- Energize the solenoid of EVD and EVD HDU for a few seconds (10 sec.)
- Switch off the solenoid of EVD HDU and check that the car has stopped
- Make the re-levelling and bring the car to the floor
- Energize the solenoid of EVD and EVD HDU for a few seconds (10 sec.)
- Switch off the solenoid of EVD and check that the car has stopped.

All the operations could be done by manually pushing the pin in the upper part of the coils.

5. Adjusting and regulation of HDU valve

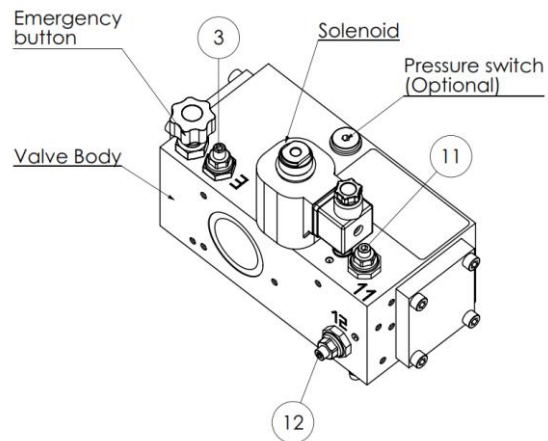

Figure 11 – Position of HDU regulation screws

In the following table the function of each item is described.

Screw	Description	Regulations
N° 3	Rod counter-pressure and rope anti-loosening device adjusting	Screw, to reduce the rod drop Unscrew, to increase the rod drop in emergency
N° 11	Start downward acceleration	Screw, to decrease the downward acceleration. Unscrew, to increase the downward acceleration
N° 12	Downward Stop	Screw to increase the stopping deceleration Unscrew to decrease the stopping deceleration

Table 5 – HDU regulations

5.1.1. Rod counter-pressure and rope anti-loosening calibration: screw N°3

In indirect acting installations, the activation of the emergency button has not to cause the rope

loosening when the car is blocked. For this reason, the remaining pressure inside the circuit must be higher than the pressure generated by the weight of the rod, the pulley and the ropes. This pressure is generated by screw no. 3: screwing it, the pressure increases; unscrewing it, the pressure decreases. The counter-pressure value which is suitable to oppose the rod downward travel is about 6/8 bar.

- Adjust the counter-pressure as follows:
 - Close the main shut-off valve and discharge the pressure with the hand button. The remaining pressure on the manometer corresponds to the rope anti-loosening counter-pressure.
 - If the pressure value needs to be increased or decreased, screw or unscrew screw n. 3 accordingly.
- If the input pressure needs to be verified:
 - Increase the pressure in the circuit with the hand pump and activate the EVD HDU;
 - Discharge the pressure with the hand button and read the remaining pressure;
 - If necessary, repeat the previous steps until the wanted counter-pressure value is reached.



Remember that, to completely activate the hand button, its plug has to be put in the relevant seat.

Screws N° 11 and N° 12 are pre-set before delivery.

6. Maintenance, inspection, repair and emergency rescue

6.1. General information

Generally, the hydraulic components are not subject to a heavy wear, they are safe and need few maintenance operations. In order to get these results, components must be correctly chosen and dimensioned on the basis of the installation characteristics.

Moreover the hydraulic oil has to suit with the room temperature and the installation traffic conditions.



It is however necessary to make, according to the scheduled times, the test and maintenance operations indicated in the periodical maintenance sheet and eliminate the detected faults immediately.



In case of irregularities or faults, which can jeopardize the safety of people and installations, the installation has to be put out of service until the defective parts are repaired or replaced

6.2. Oil leakage and car lowering

Oil leakage in the hydraulic circuit causes the car to lower with respect to the floor level, even without any control, and the intervention of the re-leveling system.



Please remember that the car lowering can also be caused by the oil cooling.

This phenomenon is evident when the installation stops, the oil is very hot and the room temperature is much lower than the oil one.



Under these conditions the electrical re-leveling system has not to be deactivated, because the car lowering could be very important.

- Here below some procedures for the main causes of the oil leakage in the hydraulic circuit.

6.2.1. Leakage inside the HDU valve group

When the installation is motionless at floor and the solenoid EVD HDU is not energized, the load pressure involves the part of the valve shown in the Figure 12 highlighted with crossed lines.

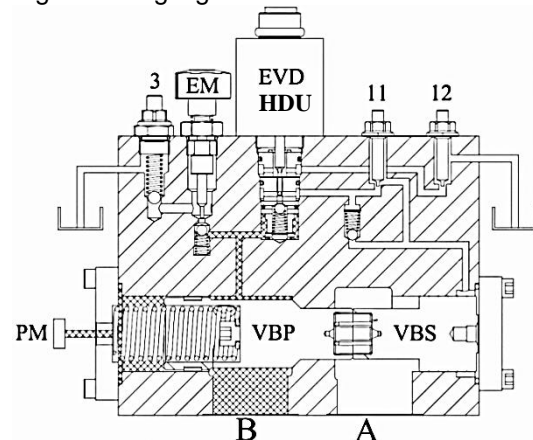

Figure 12 - Cross section of HDU valve

Legend:

EVD HDU = Downward travel electro-valve of HDU

VBP/VBS = Downward pilot valves

PR = Inlet for the pressure switch

VEM = Manual emergency valve

VP = Rupture valve

FR = Shut-off valve filter

PM = Hand pump

3 = Rod counter-pressure and rope anti-loosening calibration: screw N°3

11 = Start downward acceleration: screw N°11

12 = Downward stop: screw N°12

The **HDU valve sealing** is proved as follows:

- When the valve temperature is the same as the room temperature, close the main line shut-off

valve and increase the pressure, using the hand pump, until twice the static pressure;

- If there are no leakages in the valve, the pressure keeps constant or decreases slowly, not more than 5/6 bar during the first 3/4 minutes and tends to settle;
- If there are leakages in the valve, the pressure decreases rapidly, more than 5/6 bar during the first 3/4 minutes and goes on decreasing up to the static pressure value;

The valve components which can be involved in possible leakages are the following:

6.2.2. Leakage inside the hand emergency valve EM

- The sealing of the emergency push button is assured by a ball whose operation can be jeopardized by dirt laying between seat and ball. Every time the emergency button is activated, an oil outflow will be noted. This outflow must stop as soon as the button is released; otherwise there can be leakages from the emergency valve or leakages from the electro-valve EVD HDU which have the same discharge point.



Following checks, including the ones explained at point 6.2.4 must be carried out with pressure inside the valve. Consequently, operate very carefully! Check the emergency valve sealing by completely unscrewing the emergency group by means of its hexagon.

Dry well the oil remained inside the hole and check that no further oil comes out from the ball (see Figure 13).

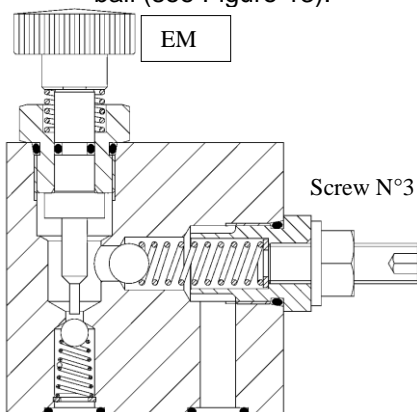

Figure 13 - Emergency unit for descent travel (EM)



If oil leakages are detected through the ball, the whole emergency block for descent travel needs to be replaced or repaired as specified in the following point.

6.2.3. Leakage inside the downward travel electro-valve EVD HDU.

The sealing ball of the downward travel valve (see Figure 14) can remain slightly open and lose oil.

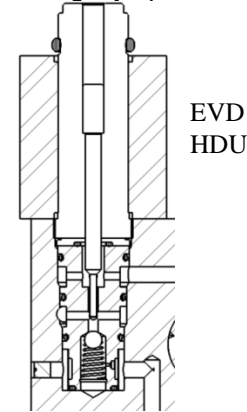

Figure 14- Electro-valve EVD HDU for downward movement



Following checks must be carried out without pressure inside the valve. It shall be therefore necessary to close the main line shut-off valve, unscrew screw no. 3 (rod counter-pressure) and press the manual emergency button in order to lower the pressure to zero.

The reasons why the downward travel valve may not work properly are the following:

- Small metal particles or dirt have got inside the coil between the tube and the cursor delaying or preventing the return movement of the coil cursor.

It is necessary to remove the coil, unscrew the mechanical part of the EVD and shake it backwards and forwards with the hand to ensure that the inside piston is free. If not, replace it.

- The EVD coil button has got caught after having been manually activated with a screwdriver and the coil cursor cannot return to its resting position. In this case it is necessary to remove the coil, unscrew the mechanical part of the EVD and push its piston completely back.
- Some metal particles lay between the ball and the sealing seat preventing the closing or damaging the sealing seat of the EVD valve. To check the EVD electro-valve sealing it is necessary to remove the coil, unscrew the mechanical part of the coil, remove the pin and the EVD aluminium valve.

At this point it is necessary to inspect the EVD valve and then proceed in the following way:

- Remove the seeger ring which blocks the spring and the ball in the lower part of the EVD valve.
- Inspect the ball seat and if it appears grooved or faulty, attempt to repair it by repositioning the ball in its proper place and clinching it by using a proper punch.



Warning: do not hammer strongly because the seat is in aluminium, and may break through. If possible, replace the balls used to clinch the seats.

- Reassemble all the components properly, reassemble the EVD valve in its seat, the pin and the coil.



Warning: reactivate the valve pressure by opening the shut-off valve and verify that there are no leakages underneath the valve.



If oil leakages are detected it will be necessary to replace the EVD valve or the whole downward travel block.

6.2.4. Piloted non-return valve VBP

The VBP valve (non-return valve) has to keep the main line closed when the car is motionless.

The perfect sealing is guaranteed by a seal placed between the two parts which compose its piston.

This seal wears with the passing of the time and can be damaged by metal particles which engrave it and hinder its sealing because they come between seat and seal.

The closing can also be slowed down by the bad running of the VBP piston because of dirt and hindered by the faulty closing of the electro-valve EVD.

Operate as follows, to get rid from VBP leakages:

1. Check that VBP piston runs well and, if necessary, remove dirt and clean with a thin cloth.
2. Check that the electro-valve EVD closes perfectly, when the coil is disconnected (see previous point)
3. Replace the VBP seal, as below described (see *Figure 15*):
 - Close the main line shut-off valve.
 - Unscrew the screw n. 3 for rod counter-pressure and take pressure back to zero using the hand operation button.
 - Remove the cover to reach VBP piston, paying attention to the spring.

- Unscrew the screw which holds the two parts of the piston tight and replace the seal placed between them. Be careful to position it in the right way.
- Reassemble all the parts paying attention to the O-Ring placed between the valve and the cover.

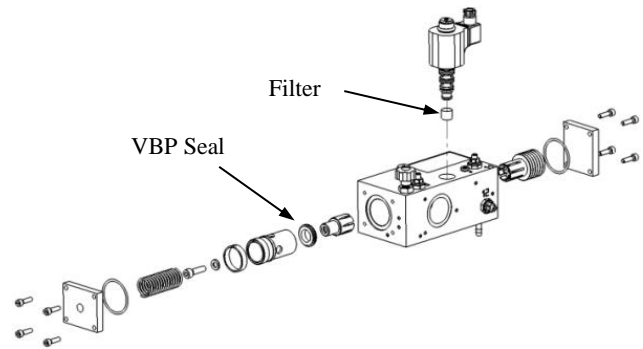

Figure 15 – Exploded view of HDU valve

6.3. Filter cleaning inside HDU valve

- With a general overhaul or when operation faults occur, clean all filters located on the electro-valves and indicated in Figure.
- To clean or replace the cartridge of the shut-off valve filter, before closing the shut-off valve, unscrew screw no. 3 and discharge the pressure, then unscrew the bottom of the filter to reach the cartridge.

7. Spare parts list and optional accessories

Spare parts

- Fittings
- Available coils: single / double
- Available voltages for coils: according to Table 4.
- Discharge pipe back to the tank (see Figure 5)

Optional accessories:

- Fittings for connection with valve
- Pressure switches (PRESSURE MIN. - MAX. - OVERLOAD) – Refer to the Instruction manual of the NL valve
- Manometer– Refer to the Instruction manual of the NL valve

8. Valve replacement

In case is necessary to replace the valve follow the instruction below:



Before disassembling or disconnecting the old HDU valve, be sure that the oil inside the HDU is not under pressure and operate as follows:

Get the car completely down on the buffers, loosen the screw no.3 of the rod counter-pressure and push the manual emergency button to bring the pressure value to "0".

Replace the valve and repeat both the adjustment and the checking as explained on previous paragraphs.



Collect the spilled oil in a proper container to prevent it from having an environmental impact and clean with a cloth.



9. TÜV Certificate: 95/16/EC – EN81-2 (example)

ZERTIFIKAT ◆ CERTIFICATE ◆ 認証証書 ◆ CERTIFICADO ◆ CERTIFICAT	Certificate no.:	ESVH 019
	Notified body:	TÜV SÜD Industrie Service GmbH Westendstr. 199 80686 München - Germany
	Applicant/ Certificate holder:	OMARLIFT S.R.L. Via F.lli. Kennedy 22/D 24060 Bagnatica (BG) – Italy
	Date of application:	2014-01-29
	Manufacturer of the test sample:	OMARLIFT S.R.L. Via F.lli. Kennedy 22/D 24060 Bagnatica (BG) – Italy
	Product:	Hydraulic valve for a brake element as part of a protection means against unintended downward car movement
	Type:	HDU 210 STAND ALONE and INTEGRATED
	Test laboratory:	TÜV SÜD Industrie Service GmbH Zentralbereich Fördertechnik-Sonderbauten Abteilung Aufzüge und Sicherheitsbauteile Gottlieb-Daimler Str. 7 70794 Filderstadt - Germany
	Date and number of the test report:	2014-07-28 ESVH 019-022
	Test specification:	EN 81-2:1998+A3:2009 (D)
	Result:	The safety component conforms to the essential safety requirements of the Directive for the respective scope of application stated on the annex (one page) to this type-examination certificate.
	Date of issue:	2014-07-28

Certification body for lifts and safety components

 Werner Rau





Subject to change without notice!



Industrie Service

Annex to the EC type-examination certificate no. ESVH 019 dated 2014-07-28

1 Scope of application

1.1 Flow, pressure, viscosity, ambient temperature

Range of flow	[l/min]	55 – 210
Range of pressure	[bar]	10 – 45
Range of viscosity	[cSt]	25 – 400
Range of ambient temperature	[° C]	0 – 65

2 Conditions

- 2.1 The graph "HDU Valves braking distance P=10 – Rev. 03" dated 2014-05-12 with certification stamp of 2014-07-28 as well as the written notes and dimension details have to be observed.
- 2.2 The above mentioned safety component represents only one part of the protective equipment against movements of the car in downward direction. Only in combination with a detection and triggering component (also two different components are possible), which must be subjected to an own type examination according to the test procedure specified in Annex F.8 of EN 81-2:1998+A3:2009 (D), the system created can fulfil the requirements for a protection means in accordance with section 9.13 of EN 81-2:1998+A3:2009 (D).
- 2.3 For each lift system the maximum possible braking distance must be determined and documented by the installer.
This can be done with the help of the graph „HDU Valves braking distance P=10 – Rev. 03" dated 2014-05-12 with certification stamp dated 2014-07-28.
The determined maximum possible braking distance as well the information in accordance with EN 81-2:1998+A3:2009 (D), section 9.13.5 and section 9.13.6 shall be checked after the installation of the lift system.
- 2.4 To fulfil the overall concept for the lift installation(s) the installer of the lift has to create a guidance for tests, add it to the documentation of the lift and provide any necessary tools or measuring devices which allow a safe test (e. g. closed landing doors by using a test plug which simulates an open door).
- 2.5 In the instruction manual of the lift it has to be written what is necessary to do if the "protection against unintended car movement" has been activated – in a way that competent persons according to section 9.13.9 of EN 81-2:1998+A3:2009 (D) can recognize it.

3 Remarks

- 3.1 The type-examination covers the housing of the braking element (hydraulic valve) and the piston only. The pump connection and the cylinder connection is not included within this type-examination.
- 3.2 In case that there is a risk of unintended car movement in the upward direction, appropriate measures must be taken by the installer.
- 3.3 The type-examination certificate may only be used in connection with the pertinent annex and the list of the authorized manufacturers (according to enclosure). This enclosure shall be updated and re-edited following information of the certificate holder.

Note: The English text is a translation of the German original. In case of any discrepancy, the German version is valid only.

2014-07-28 / IS-FSA-STG/Be / AN_ESVH019_140728_en.docx

Seite 1 von 1



10. TÜV Certificate: 2014/33/EU – EN81-20/50 (example)

ZERTIFIKAT ◆ CERTIFICATE ◆ 認証証書 ◆ CERTIFICADO ◆ CERTIFICAT



Industrie Service

EU TYPE-EXAMINATION CERTIFICATE

According to Annex IV, Part A of 2014/33/EU Directive

Certificate No.: EU-UCM 019

Certification Body of the Notified Body: TÜV SÜD Industrie Service GmbH
Westendstr. 199
80686 Munich – Germany
Identification No. 0036

Certificate Holder: OMARLIFT S.R.L
Via F.lli. Kennedy 22/D
24060 Bagnatica (BG) – Italy

Manufacturer of the Test Sample: OMARLIFT S.R.L
Via F.lli. Kennedy 22/D
24060 Bagnatica (BG) – Italy
(Manufacturer of Serial Production – see Enclosure)

Product: Hydraulic valve for a brake element as part of a protection means against unintended downward car movement

Type: HDU 210 STAND ALONE and INTEGRATED

Directive: 2014/33/EU

Reference Standards: EN 81-20:2014
EN 81-50:2014
EN 81-2:1998+A3:2009

Test Report: EU-UCM 019-022 of 2015-09-18

Outcome: The safety component conforms to the essential health and safety requirements of the mentioned Directive as long as the requirements of the annex of this certificate are kept.

Date of Issue: 2015-09-18

Date of Validity: from 2016-04-20

Achim Janocha
Certification Body "lifts and cranes"



TUV®

**Annex to the EU Type-Examination Certificate
No. EU-UCM 019 of 2015-09-18**



1 Scope of application

Hydraulic valve for a brake element as part of a protection means against unintended downward car movement, type HDU 210 STAND ALONE and INTEGRATED

Flow, pressure, viscosity, ambient temperature

Range of flow	[l/min]	55 – 210
Range of pressure	[bar]	10 – 45
Range of viscosity	[cSt]	25 – 400
Range of ambient temperature	[° C]	0 – 65

2 Terms and Conditions

- 2.1 The graph "HDU Valves braking distance P=10 – Rev. 03" dated 2014-05-12 with certification stamp of 2015-09-18 as well as the written notes and dimension details have to be observed.
- 2.2 The above mentioned safety component represents only one part of the protective equipment against movements of the car in downward direction. Only in combination with a detection and triggering component (also two different components are possible), which must be subjected to an own type examination according to the test procedure specified in EN 81-2:1998+A3:2009 (D), Annex F.8 / EN 81-50:2014 (D), section 5.8, the created system can fulfil the requirements for a protection means in accordance with EN 81-2:1998+A3:2009 (D), section 9.13 / EN 81-20:2014 (D), section 5.6.7.
- 2.3 For each lift system the maximum possible braking distance must be determined and documented by the installer.
This can be done with the help of the graph „HDU Valves braking distance P=10 – Rev. 03" dated 2014-05-12 with certification stamp dated 2015-09-18.
The determined maximum possible braking distance as well the information in accordance with EN 81-2:1998+A3:2009 (D), section 9.13.5 and section 9.13.6 / EN 81-20:2014 (D), section 5.6.7.5 and section 5.6.7.6 shall be checked after the installation of the lift system.
- 2.4 To fulfil the overall concept for the lift installation(s) the installer of the lift has to create a guidance for tests, add it to the documentation of the lift and provide any necessary tools or measuring devices which allow a safe test (e. g. closed landing doors by using a test plug which simulates an open door).
- 2.5 In the instruction manual of the lift it has to be written what is necessary to do if the "protection against unintended car movement" has been activated – in a way that competent persons according to EN 81-2:1998+A3:2009 (D), section 9.13.9 / EN 81-20:2014 (D), section 5.6.7.9 can recognize it.
- 2.6 The EU type-examination certificate may only be used in combination with the corresponding annex and enclosure (List of authorized manufacturer of the serial production). The enclosure will be updated immediately after any change by the certification holder.

3 Remarks

- 3.1 This EU type-examination certificate was issued according to the following standards:
 - EN 81-2:1998 + A3:2009 (D), part 9.13
 - EN 81-2:1998 + A3:2009 (D), annex F.8
 - EN 81-20:2014 (D), part 5.6.7
 - EN 81-50:2014 (D), part 5.8

A revision of this EU type-examination certificate is inevitable in case of changes or additions of the above mentioned standards or of changes of state of the art.
- 3.2 The EU type-examination covers the housing of the braking element (hydraulic valve) and the piston only. The pump connection and the cylinder connection is not included within this type-examination.
- 3.3 In case that there is a risk of unintended car movement in the upward direction, appropriate measures must be taken by the installer.

Attachment 1 : Conformity verification of HDU as a brake application

! It is always necessary to verify and evaluate the conformity of the HDU application valve to the range of parameters chosen for certifying the elevator.

A1.1. Premise:

The HDU is a protection device preventing unintended car movements, and it is subjected to the dispositions provided by the normative EN81-2 §9.13 and the normative EN81-20 §5.6.7, to which you must refer.

Specifically:

- The device shall stop the car leaving a free distance from landing sill to car door lintel not less than 1000mm. Considering the minimum permitted height of the doors (2000mm), this entails the reduction from 1200mm to 1000mm of the space to stop the car (*Figure 16*).
- These values shall be guaranteed with any load in the elevator, up to 100% of rated load.
- The device shall NOT protect from failure in suspension ropes, oil pipes and cylinder, which determine the free fall of the elevator. It shall protect only from a failure in any single hydraulic component, which determine an unintended movement of the cabin (UCM).

! After the installation of the HDU, it is mandatory to verify the compliance of the solution engineered with the normative requirements, by measuring the stopping distance after deactivation of the EVD HDU solenoid during a downward travel under the most critical conditions.

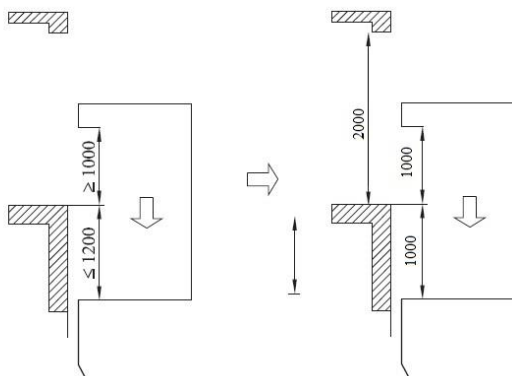

Figure 16 – HDU available stopping distance

A1.2. Determination of system characteristics:

The real behavior of the elevator in terms of acceleration and speed during the unintended car movement phase (UCM) depends on the oil temperature and the specification of the system (cylinder, pipes, valves, etc.).

We define:

- **Pmin**= minimum oil pressure to which you intend to certify the elevator system (e.g.:10 bar)
- **Tmin**= minimum oil temperature to which you intend to certify the elevator system (e.g.:10°C)
- **Ttest**= oil temperature to which the test described in this procedure will be performed.

! **Ttest** should be as close as possible to **Tmin** at which you intend to certify the elevator

- **h1, h2**= distance (height) in meters between the floors used for the test (e.g.:3,5m)
- **S_U**= distance in meters between the sensor which detects the UCM and the related floor (e.g.:0,25m)
- **H**= height of the door (e.g.:2000mm)

! On the basis of experimental tests, **Omarlift has identified the worst configuration for the HDU valve in terms of stopping distance, under the condition of Pmin and Tmin**, when the stopping time increases.

Therefore, when it is impossible to perform a stopping test at Tmin and Pmin, the behavior has to be estimated on the basis of some alternative measurements described here below.

PROCEDURE:

With reference to *Figure 167*:

A1.2.1. With the elevator in empty conditions (Pmin) and Ttest, measure the time **t2** necessary to reach the floor below, from a standing start.

To do this, after placing the elevator to the next floor in upward direction, manually activate the EVD descent pilot by pressing it (+EVD HDU if already present), and release it when the elevator passes from the floor immediately below.

Measure the time **t2** from the descent pilot activation and the crossing of the floor immediately below.

A1.2.2. With the elevator in empty conditions (Pmin) and Ttest, measure the time **t1** necessary to pass at its natural stabilized speed from a floor to the floor immediately below.

To do this, after placing the elevator to the second floor in upward direction, manually activate the EVD descent pilot by pressing it (+EVD HDU if already present), and release it when the elevator passes from the ground floor.

Measure the time **t1** from the crossing of the first floor and the crossing of the ground floor.

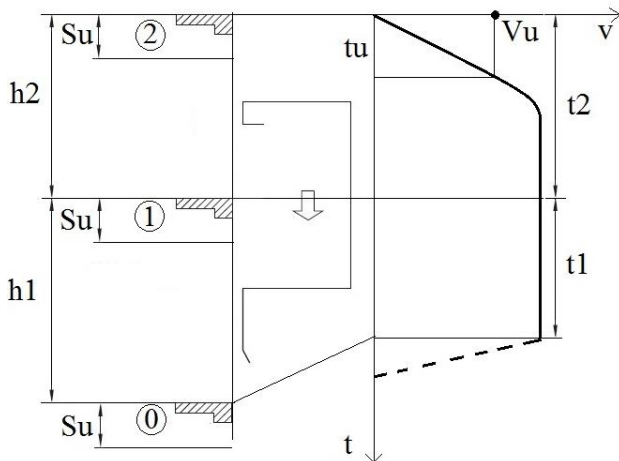

Figure 17 – Symbols for V_u calculation

A1.2.3. Determine the expected speed at the end of the UCM's individuation length, V_u :

$$V_u = \sqrt{\frac{h_1^2 * S_u}{t_1 * (h_1 * t_2 - h_2 * t_1)}}$$

The true speed value, V_u at T_{min} , will be less than the calculated value, because of the increased oil viscosity at low temperature.

A1.2.4. On the specific graph of the used HDU valve, by using the curve related to temperature T_{min} to which you want to certify the system, at the intersection with the speed V_u , determine the expected stopping length, S_{STOP} .

A1.3. Results evaluation

Calculate:

$$H_u = H - 1000 \text{ (mm)}$$

If H_u is greater than 1200, take the value 1200mm

Using the value deduced from the graph, if:

- $S_{STOP} < H_u - S_u$ (mm) → **OK**

The HDU valve is expected to comply with the requirements at the minimum temperature.

- $S_{STOP} > H_u - S_u$ (mm) → **NOT CONFORM**

The HDU valve could be not compliant with the normative at the minimum temperature.

It is necessary, therefore, to increase the minimum oil temperature, or change the chosen device.

If it is possible, redo the evaluation with more accuracy, repeating the test after cooling the oil to the minimum temperature and measuring the real value of S_{STOP}

A1.4. CALCULATION EXAMPLES

A1.4.1. Example 1

Elevator data:

- $P_{min} = 15 \text{ bar}$ (press. in empty condition)
- $T_{min} = 0^\circ \text{C}$ (minimum oil temperature to which you want to certify the elevator)
- $h_1 = 3,2 \text{ m}$ (floor distance 0-1)
- $h_2 = 3,1 \text{ m}$ (floor distance 1-2)
- Valve HDU 600 (type of valve)
- $S_u = 0,25 \text{ m}$ (position of UCM sensor from the floor)
- $H = 2 \text{ m} = 2000 \text{ mm}$ (height of the doors)

From the test, according to the PROCEDURE, you obtained these values at empty conditions:

- $T_{test} = 20^\circ \text{C}$ (oil temperature to which the downward tests were performed)
- $t_1 = 3,0 \text{ s}$ (time to cover one floor at the natural stabilized speed)
- $t_2 = 4,0 \text{ s}$ (time to cover one floor from a standing start)

Calculate the expected speed of the elevator at which the HDU will be activated, as a consequence of the fixed position (S_u) for the UCM's sensor:

$$V_u = \sqrt{\frac{(3,2)^2 * 0,25}{3 * (3,2 * 4 - 3,1 * 3)}} = 0,494 \text{ m/s}$$

Using the calculated V_u value, entering in the graph for the HDU valves at $P=10 \text{ bar}$, you will deduce the value of the stopping distance S_{STOP} by crossing the speed value with the curve related to the minimum temperature to which you want to certify the elevator.

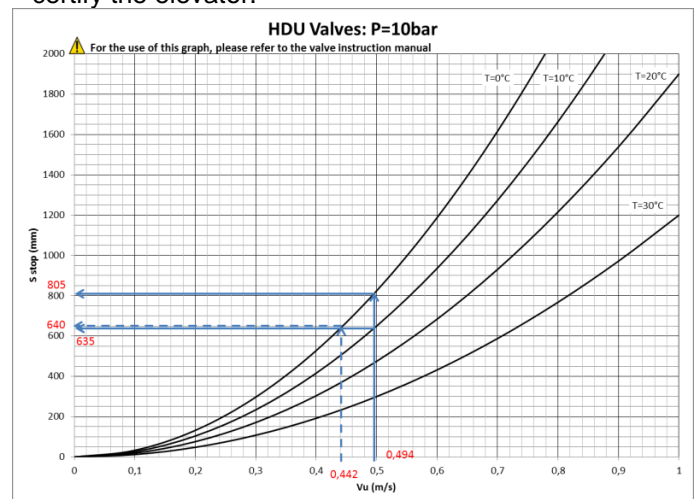

RESULTS:

With the sensor positioned at $S_u = 0,25 \text{ m} = 250 \text{ mm}$

$H_u = 2000 - 1000 = 1000 \text{ mm}$

$1000 - S_u = 750 \text{ mm}$

$S_{STOP} = 805 \text{ mm} > 750 \text{ mm}$ at 0°C → **NON CONFORM**

$S_{STOP}=635\text{mm}<750$ at **10°C** → **OK**

The elevator can be certified with HDU only at 10°C

You can estimate an extension of the range to:

$S_{STOP}=0.5*(805+635)=720\text{mm}$ at **5°C** → **OK**

but this value shall be confirmed by a stopping test at oil temperature $T_{oil}=5^{\circ}\text{C}$.

There are more possibilities to improve the performances:

- move the UCM sensor closer to the floor, i.e. reduce the S_u value. As a consequence, there will be a decreasing of V_u and of stopping distance S_{STOP} at the same temperature, see A1.4.3. Example 3.
- increase the minimum temperature to which you want to certify the elevator system, as shown before
- adopt doors with increased height, see A1.4.2. Example 2.

A1.4.2. Example 2

Elevator data:

See A1.4.1. Example 1 except:

- $H=2,3\text{m}=2300\text{mm}$ (door height)

Calculate:

$$V_u = \sqrt{\frac{(3,2)^2 * 0.25}{3 * (3,2 * 4 - 3,1 * 3)}} = 0.494\text{m/s}$$

$H_u=2300-1000=1300>1200\text{mm}$

Fix the max acceptable value:

$H_u=1200\text{mm}$

$H_u-S_u=1200-250=950\text{mm}$

From the graph of HDU valve

$S_{STOP}=805\text{mm}<950$ at **0°C** → **OK**

The elevator can be certified at $T_{min}=0^{\circ}\text{C}$, with increased height of the doors (2300mm, but also 2200mm is OK!)

A1.4.3. Example 3

Elevator data:

See A1.4.1. Example 1, except:

- $S_u=0,2\text{m}=200\text{mm}$ (position of UCM sensor from the floor)

Calculate:

$$V_u = \sqrt{\frac{(3,2)^2 * 0.2}{3 * (3,2 * 4 - 3,1 * 3)}} = 0.442\text{m/s}$$

$H_u=2000-1000=1000<1200\text{mm}$

$H_u-S_u=1000-200=800\text{mm}$

From the graph of HDU valve

$S_{STOP}=640\text{mm}<800$ at **0°C** → **OK**

The elevator can be certified at $T_{min}=0^{\circ}\text{C}$, with reduced distance of the UCM sensor from the floor (200mm)

HDU Valves: P=10bar

! For the use of this graph, please refer to the valve instruction manual

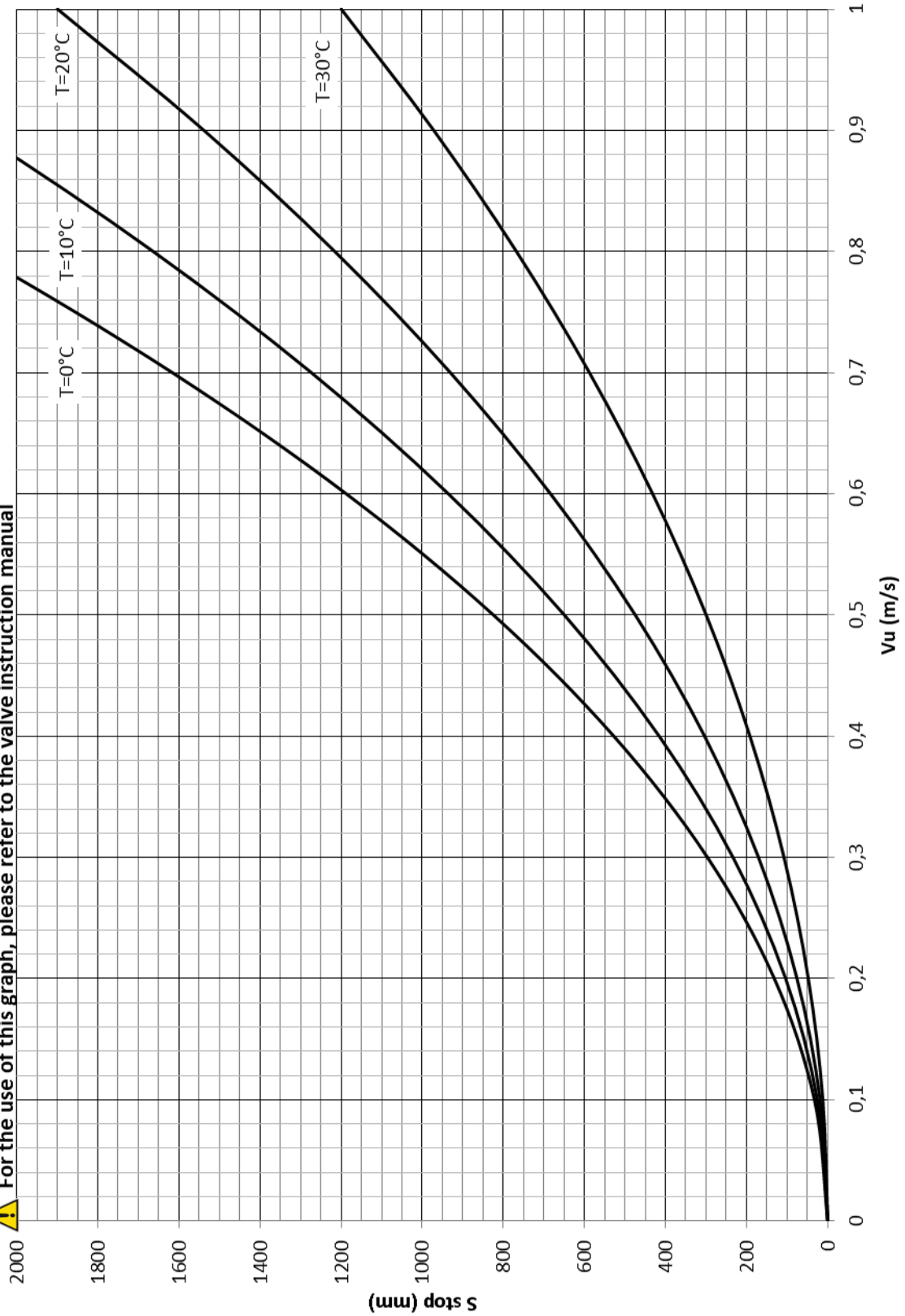

! If the minimum pressure of the considered system is $P_{min} > 10\text{bar}$, the real values of the stopping distance will be lower than these shown in the graph.

OMARLIFT SRL
Via F.lli Kennedy, 22/D
I – 24060 Bagnatica (BG) – ITALY
Phone +39 035 689611
Fax +39 035 689671
E-mail: info@omarlift.eu
Web: <http://www.omarlift.eu>